

Refrigeration Temperature Controller

■ Features

- Standard installation size for refrigeration and air-cooling panels (W70.3×H28.2mm)
- Various compressor load current capacity: 5A, 16A, 20A
- Various user-friendly functions:
 - Defrost sync function: simultaneous defrost operation of multiple controllers (up to 6 units)
 - RTC (Real Time Clock) function: night mode operation and real-time defrost control
 - Built-in alarm function
- Remote monitoring of real-time temperature and output control (using TFD series remote display unit, sold separately)
- Communication output models available: RS485 (Modbus RTU)
- Parameter configuration via PC (RS485 communication)
 - DAQMaster software included (comprehensive device management software)
- IP65 protection structure (IEC standard): front panel only



⚠ Please read "Safety Considerations" in the instruction manual before using.



■ Manual

- Visit our website (www.autonics.com) to download user manual and communication manual.
- User manual describes for specifications and function, and communication manual describes for RS485 communication (Modbus RTU protocol) and parameter address map data.

■ Comprehensive Device Management Program (DAQMaster)

- DAQMaster is comprehensive device management program. It is available for parameter setting, monitoring, and user parameter group setting, parameter mask setting for only TF3 Series.
- Visit our website (www.autonics.com) to download user manual and comprehensive device management program.

< Computer specification for using software >

Item	Minimum requirements
System	IBM PC compatible computer with Intel Pentium III or above
Operating system	Microsoft Windows 98/NT/XP/Vista/7/8/10
Memory	256MB or more
Hard disk	More than 1GB of free hard disk space
VGA	1024×768 or higher resolution display
Others	RS-232 serial port (9-pin), USB port

< DAQMaster screen >



SENSORS

CONTROLLERS

MOTION DEVICES

SOFTWARE

(J) Temperature Controllers

(K) SSRs

(L) Power Controllers

(M) Counters

(N) Timers

(O) Digital Panel Meters

(P) Indicators

(Q) Converters

(R) Digital Display Units

(S) Sensor Controllers

(T) Switching Mode Power Supplies

(U) Recorders

(V) HMIs

(W) Panel PC

(X) Field Network Devices

TF3 Series

Ordering Information

TF	3	3	3	4	H	T	
							Option function ^{※2}
							Compressor load capacity
							Power supply
							Output
							Number of input channels
							Digits
							Item
							No-mark
							S
							T
							R ^{※3}
							A ^{※3}
							G ^{※1}
							A
							H
							1
							4
							1CH
							1CH, 3CH
							1
							2
							3
							1
							3
							3
							TF

※1: Only for 1CH input, compressor output model (TF31-1□G).

※2: Only for 3CH input model (TF33-□□□-□). Option function is varied by compressor load capacity and contact.

Option function	Synchronize defrost function	RS485 communication	RTC function	RS485 communication+ RTC function	No option
Compressor load capacity & contact					
Compressor 5A 1a contact	● (TF33-□□A-S)	● (TF33-□□A-T)	—	● (TF33-3□A-A)	—
Compressor 16A 1c contact	—	—	● (TF33-3□H-R)	—	● (TF33-□□H)

※3: Except compressor+defrost or auxiliary (alarm/evaporator-fan) output model (TF33-2□□-□)

※Only for 3CH input, compressor+defrost+auxiliary (alarm/evaporator-fan) output model (TF33-3□□-□) supports buzzer.

Remote Display Unit (TFD Series, Sold Separately)



Remote display unit (TFD) displays current temperature or output status of TF3 at remote place.

TFD cable is TFD-3: 3m, TFD-5: 5m.

Connect the phone-jack of remote display unit (TFD) to the data loader port of TF3.

This unit is dedicated for TF3 Series and it does not directly communicate with upper devices (PC, PLC, etc.)



If TFD communication with TF3 error occurs, TFD flashes display component for 1 sec. Check the connection with TF3.

※When connecting TFD to the data loader port of TF3, you cannot connect Autonics SCM-US (USB to Serial converter, sold separately). for communication. Use SCM-US48I(USB to RS485 converter, sold separately), SCM-38I(RS232C to RS485 converter, sold separately).



Refrigeration Temperature Controller

■ Specifications

○ TF3 Series

Model	TF31-□□□□	TF33-□□□□-□	
Number of channels	1CH	3CH	
Power supply	AC power	100-240VAC~ 50/60Hz	
	AC/DC power	24VAC~ 50/60Hz, 12-24VDC=	
Allowable voltage range	90 to 110% of rated voltage		
Power consumption	AC power	Max. 8VA (100-240VAC~ 50/60Hz)	
	AC/DC power	Max. 5VA (24VAC~ 50/60Hz), Max. 3W (12-24VDC=)	
Display method	7 Segment LED method (red)		
Character size (W×H)	9.4×19.3mm		
Input type	NTC	5kΩ/10kΩ	
	RTD	DPt100Ω	
Sampling period	500ms		
Display accuracy	· At room temp. (23°C±5°C): ±1°C±1 digit · Out of room temp. range: ±2°C±1 digit		
Control output	Compressor (COMP)	250VAC~ 5A, 30VDC= 5A, 1a / 250VAC~ 16A, 24VDC= 16A, 1c / 250VAC~ 20A 1a	
	Defrost (DEF)	250VAC~ 10A, 24VDC= 10A, 1a	
	Auxiliary (AUX)	250VAC~ 5A, 30VDC= 5A, 1a	
Communication output	—	RS485 communication output (Modbus RTU)	
Digital input	Contact input: ON max. 1kΩ, OFF min. 100kΩ No contact input: ON residual voltage: max. 1V, OFF leakage current: max. 1mA, outflow current: 4μA		
Control method	ON/OFF control		
Hysteresis	0.5 to 5.0°C, 2 to 10°F variable		
Relay life cycle	Compressor (COMP)	5A 1a	Mechanical: 5,000,000 operations, Electrical: 50,000 operations (250VAC 5A)
		16A 1c	Mechanical: 20,000,000 operations, Electrical: 30,000 operations (250VAC 16A)
		20A 1a	Mechanical: 10,000,000 operations, Electrical: 100,000 operations (250VAC 20A)
	Defrost (DEF)	Mechanical: 20,000,000 operations, Electrical: 100,000 operations (250VAC 10A)	
Auxiliary (AUX)	Mechanical: 5,000,000 operations, Electrical: 50,000 operations (250VAC 5A)		
Memory retention	Approx. 10 years (non-volatile memory method)		
Insulation resistance	Min. 100MΩ (at 500VDC megger)		
Dielectric strength	AC power	3000VAC 50/60Hz for 1 min (between all terminals and case, power and input circuit)	
	AC/DC power	1000VAC 50/60Hz for 1 min (between all terminals and case, power and input circuit)	
Noise resistance	Square-wave noise by the noise simulator (pulse width: 1μs) ±2kV R-phase and S-phase		
Vibration	1.5mm amplitude at frequency of 10 to 55Hz (for 1 min) in each X, Y, Z direction for 2 hours		
Environment	Ambient temperature	-10 to 50°C, storage: -20 to 60°C	
	Ambient humidity	35 to 85%RH, storage: 35 to 85%RH	
Accessories	Bracket: 2, NTC sensor (5kΩ): 1		
Protection structure	IP65 (front case)		
Approval	  		
Weight ^{※1}	Approx. 207g (approx. 105g)		

○ Remote display unit [TFD]

Model	TFD-3	TFD-5	
Power supply	3.3VDC=		
Power consumption	Max. 1W		
Display method	7 Segment LED method (red)		
Communication method	Serial (TTL Level), Half duplex		
Communication cycle	100ms		
Cable	Ø2.5mm, 3m	Ø2.5mm, 5m	
Vibration	1.5mm amplitude at frequency of 10 to 55Hz (for 1 min) in each X, Y, Z direction for 2 hours		
Environment	Ambient temp.	-10 to 50°C, storage: -20 to 60°C	
	Ambient humi.	35 to 85%RH, storage: 35 to 85%RH	
Protection structure	IP67		
Approval	 		
Weight ^{※1}	Approx. 77g (approx. 48g)		

※1: The weight includes packaging. The weight in parentheses is for unit only.
The weight is varied by model option.

※Environment resistance is rated at no freezing or condensation.

SENSORS

CONTROLLERS

MOTION DEVICES

SOFTWARE

(J) Temperature Controllers

(K) SSRs

(L) Power Controllers

(M) Counters

(N) Timers

(O) Digital Panel Meters

(P) Indicators

(Q) Converters

(R) Digital Display Units

(S) Sensor Controllers

(T) Switching Mode Power Supplies

(U) Recorders

(V) HMIs

(W) Panel PC

(X) Field Network Devices

TF3 Series

Connections

※Use crimp terminals of size specified below.

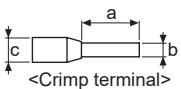

<Crimp terminal>

Terminal number	a	b	c
General	1 to 4	4 to 6mm	Max. 1.7mm
TF3□□□H	5 to 10	6 to 8mm	Max. 2.3mm
TF3□□□A	5 to 6	6mm	Max. 1.9mm
	7 to 10	6 to 8mm	Max. 2.3mm
TF3□□□G	6 to 7	6 to 8mm	Max. 2.3mm
General	11 to 12	6mm	Max. 1.9mm

TF31-1□G

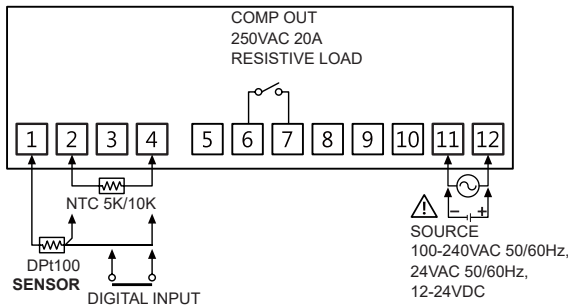

TF31-□□A

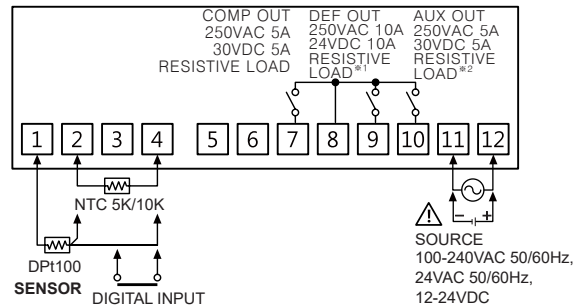

TF31-□□H

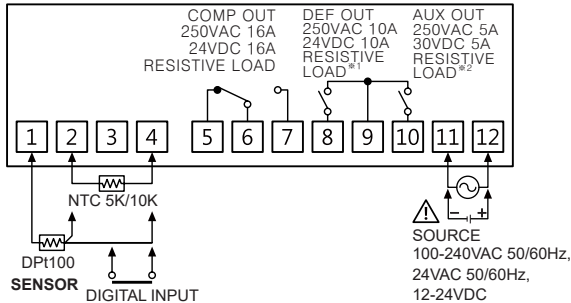

TF33-□□A-□

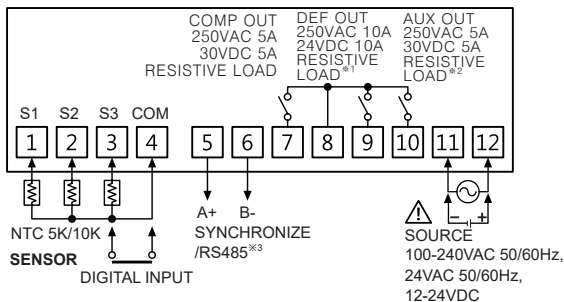

TF33-□□H-□

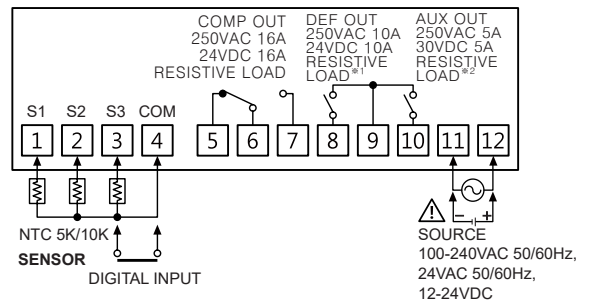

※1: Only for compressor+defrost or auxiliary (alarm/evaporator-fan) output model (TF3□-2□□-□), compressor+defrost+auxiliary (alarm/evaporator-fan) output model (TF3□-3□□-□).

※2: Only for compressor+defrost+auxiliary (alarm/evaporator-fan) output model (TF3□-3□□-□).

※3: Only for synchronize defrost function model (TF33-□□A-S), or RS485 communication model (TF33-□□A-T/A).

Refrigeration Temperature Controller

Dimensions

TF3 Series

(unit: mm)

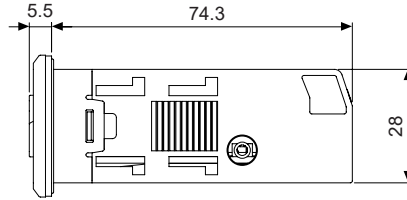
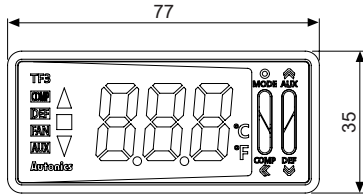

NTC sensor (5kΩ)

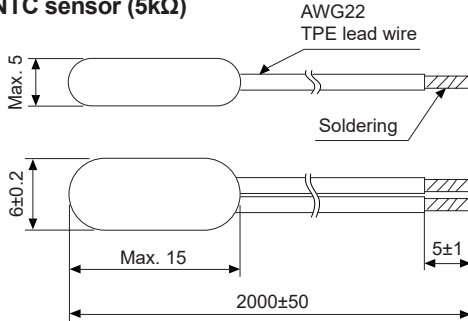

Bracket

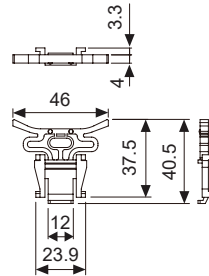

Panel cut-out

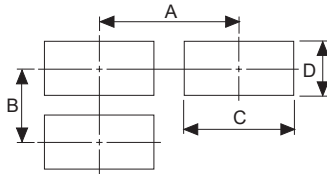

(unit: mm)

Series	Size	A	B	C	D
TF3		Min. 100 ^{※1}	Min. 55	70.3 ^{+0.7} ₀	28.2 ^{+0.5} ₀
TFD		Min. 65	Min. 40	45.7 ^{+0.6} ₀	25.4 ^{+0.3} ₀

※1. When connecting remote display unit (TFD), or SCM-US, Min. 120

Sold Separately

TFD

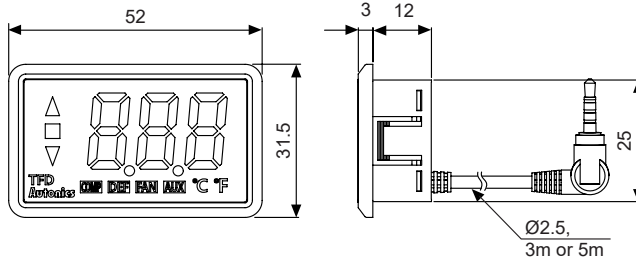

Communication converter

SCM-WF48

(Wi-Fi to RS485-USB wireless communication converter)



SCM-US481

(USB to RS485 converter)



SCM-381

(RS232C to RS485 converter)



SCM-US

(USB to Serial converter)



SENSORS
CONTROLLERS
MOTION DEVICES
SOFTWARE

(J) Temperature Controllers
(K) SSRs
(L) Power Controllers
(M) Counters
(N) Timers
(O) Digital Panel Meters
(P) Indicators
(Q) Converters
(R) Digital Display Units
(S) Sensor Controllers
(T) Switching Mode Power Supplies
(U) Recorders
(V) HMIs
(W) Panel PC
(X) Field Network Devices

TF3 Series

Product Mounting

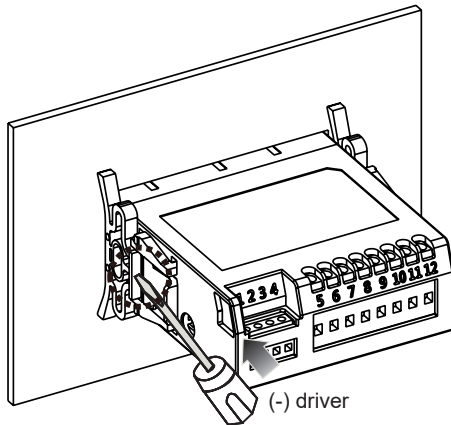

Insert the unit into a panel, fasten the bracket by pushing with tools with a (-) driver.

Unit Description

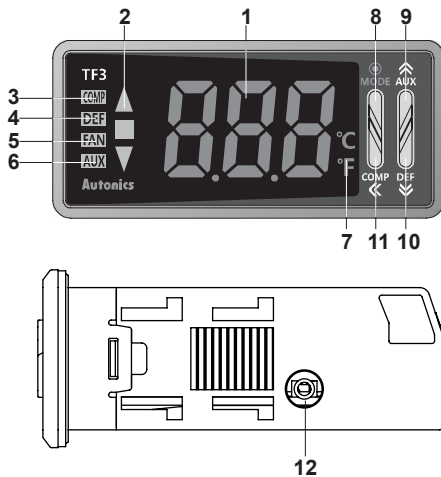

1. Present value (PV) display component (red):

- RUN mode: Displays present value (PV).
- Setting mode: Displays parameter and setting value.

2. Deviation indicator (■: green, ▼/▲: red):

Displays deviation of present value (PV) based on setting value (SV).

PV deviation temperature	Deviation display
More than 1.8°C	▲ indicator turns ON
Within ±1.8°C	■ indicator turns ON
Less than -1.8°C	▼ indicator turns ON

3. Compressor (COMP) output indicator (green):

Turns ON for compressor output. In case of compressor protection operation and output does not turn ON, it flashes. When operating compressor continuously, it turns ON for 2 sec, and turns OFF for 1 sec.

4. Defrost (DEF) output indicator (green):

Turns ON for defrost output. Flashes for defrost delay operation.
Turns ON for 2 sec and OFF for 1 sec for manual defrost or Power ON defrost.

5. Evaporator-fan (FAN) output indicator (green):

Turns ON for evaporator-fan output. Flashes for delay operation of evaporator-fan output.

6. Auxiliary (AUX) output indicator (green):

Turns ON for alarm output. Flashes for delay operation of alarm output.

7. Unit indicator (red):

Displays temperature unit set at temperature unit [UNIT] of parameter 1 group.

8. (MODE) key:

Used for entering parameter setting group, returning RUN mode, moving parameter or saving SV.

9. (AUX) key:

Used for entering SV setting group or changing setting value.

Hold the key over 3 sec to select active/inactive auxiliary output in RUN mode.

10. (DEF) key:

Used for entering SV setting group or changing setting value.

Hold the key over 3 sec to execute/stop manual defrost in RUN mode.

11. (COMP) key:

Used for entering SV setting group, changing setting value, moving digits.

Hold the key over 3 sec to active/inactive compressor output in RUN mode.

When buzzer alarm occurs, press the key once to stop the sound. (Only for 3CH input, compressor+defrost+auxiliary (alarm/evaporator-fan) output model (TF33-3□□□□□) supports buzzer.

Buzzer [BUZ] of parameter 1 group is set as [ON])

12. Data loader port:

It is for displaying TF3 data at remote display unit (TFD) by connecting phone-jack.

In other case, for connecting Autonics SCM-US (USB/Serial converter, sold separately),

it is a PC loader port of serial communication for parameter setting or monitoring by PC.

Refrigeration Temperature Controller

Front Panel Display When Power Is On

When power supplies to the unit, whole display part flashes approx. 1 sec. The display part displays model specification (no. of input CHs, output, power supply, compressor load capacity, option function), flashes input type twice and the unit returns to RUN mode to operate.

Model specification display is same as the unit model name. (E.g.: TF33-34A-A model)

1. Whole display part



2. Series



3. No. of input CHs/Output/Power supply



4. Compressor load capacity/Option function



5. Run mode



Sensor input error



Normal operation

SV Setting

You can set the temperature to control with the \leftarrow , \rightarrow , \uparrow keys.

Set range is within SV low-limit value [\downarrow 5 \downarrow] to SV high-limit value [H5 \downarrow].

E.g.) In case of changing SV from 19°C to 10°C



Press any key among the \leftarrow , \rightarrow , \uparrow in RUN mode to enter into SV setting mode. Last digit (10⁰ digit) on SV display part flashes.



Press the \leftarrow key to move digit. (10⁰ → 10¹ → 10² → 10³ → 10⁰)



Press the \rightarrow , \uparrow key to raise or lower the set value. (9 → 0)



Press the \odot (MODE) key to save the set value. (If there is no additional key operations in 3 sec, the changed SV is automatically saved.)

Input Type and Range

Input type		Decimal point	Display method	Temperature range (°C)	Temperature range (°F)
Thermistor (NTC)	NTC 5kΩ	1	n 5H	-40 to 99	-40 to 212
		0.1	n 5L	-40 to -20 -19.9 to 99.9	-40 to -20 100 to 212
	NTC 10kΩ	1	n 1H	-40 to 99	-40 to 212
		0.1	n 1L	-40 to -20 -19.9 to 99.9	-40 to -20 100 to 212
RTD*1	DPt 100Ω	1	d P.H	-99 to 99	-148 to 212
		0.1	d P.L	-99 to -20 -19.9 to 99.9*2	-148 to 212

*TF3 Series displays only 3 digits. If PV decimal number of shaded temperature range is out of 3 digit, TF3 does not display the numbers below decimal point. You can check it at the comprehensive device management program (DAQMaster) by communicating via PC.

*1: Only for 1CH input model (TF31-□□□).

*2: If PV with "-" sign is over 3 digits (e.g.: -99.9), the numbers below decimal point does not display.

You can check it at the comprehensive device management program (DAQMaster) by communicating via PC.

SENSORS

CONTROLLERS

MOTION DEVICES

SOFTWARE

(J) Temperature Controllers

(K) SSRs

(L) Power Controllers

(M) Counters

(N) Timers

(O) Digital Panel Meters

(P) Indicators

(Q) Converters

(R) Digital Display Units

(S) Sensor Controllers

(T) Switching Mode Power Supplies

(U) Recorders

(V) HMIs

(W) Panel PC

(X) Field Network Devices

Parameter Group

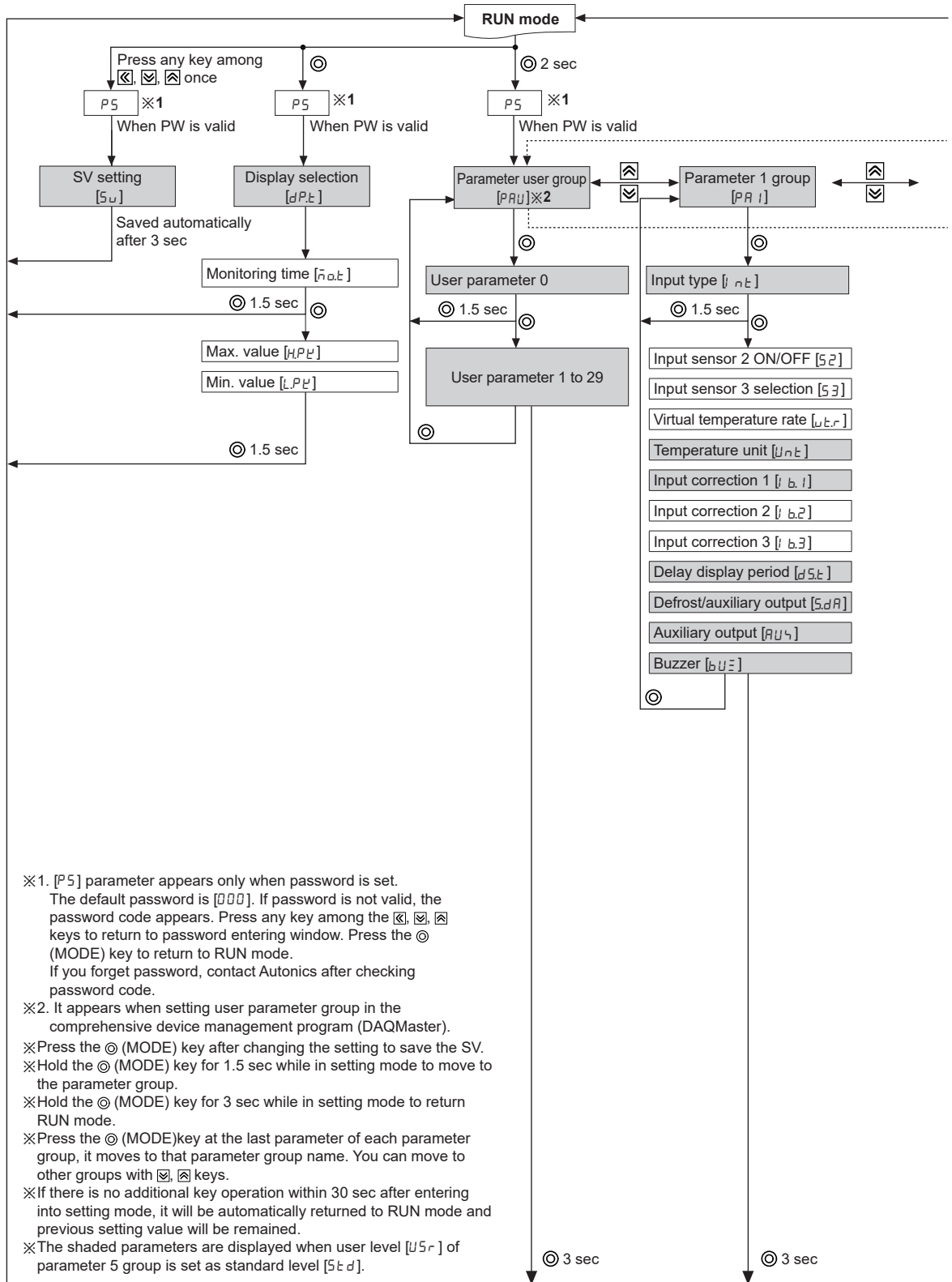

- ※1. [P5] parameter appears only when password is set.
The default password is [000]. If password is not valid, the password code appears. Press any key among the \leftarrow , \rightarrow , \rightarrow keys to return to password entering window. Press the \odot (MODE) key to return to RUN mode.
If you forget password, contact Autonics after checking password code.
- ※2. It appears when setting user parameter group in the comprehensive device management program (DAQMaster).
- ※Press the \odot (MODE) key after changing the setting to save the SV.
- ※Hold the \odot (MODE) key for 1.5 sec while in setting mode to move to the parameter group.
- ※Hold the \odot (MODE) key for 3 sec while in setting mode to return RUN mode.
- ※Press the \odot (MODE) key at the last parameter of each parameter group, it moves to that parameter group name. You can move to other groups with \leftarrow , \rightarrow keys.
- ※If there is no additional key operation within 30 sec after entering into setting mode, it will be automatically returned to RUN mode and previous setting value will be remained.
- ※The shaded parameters are displayed when user level [U5r] of parameter 5 group is set as standard level [5td].

Refrigeration Temperature Controller

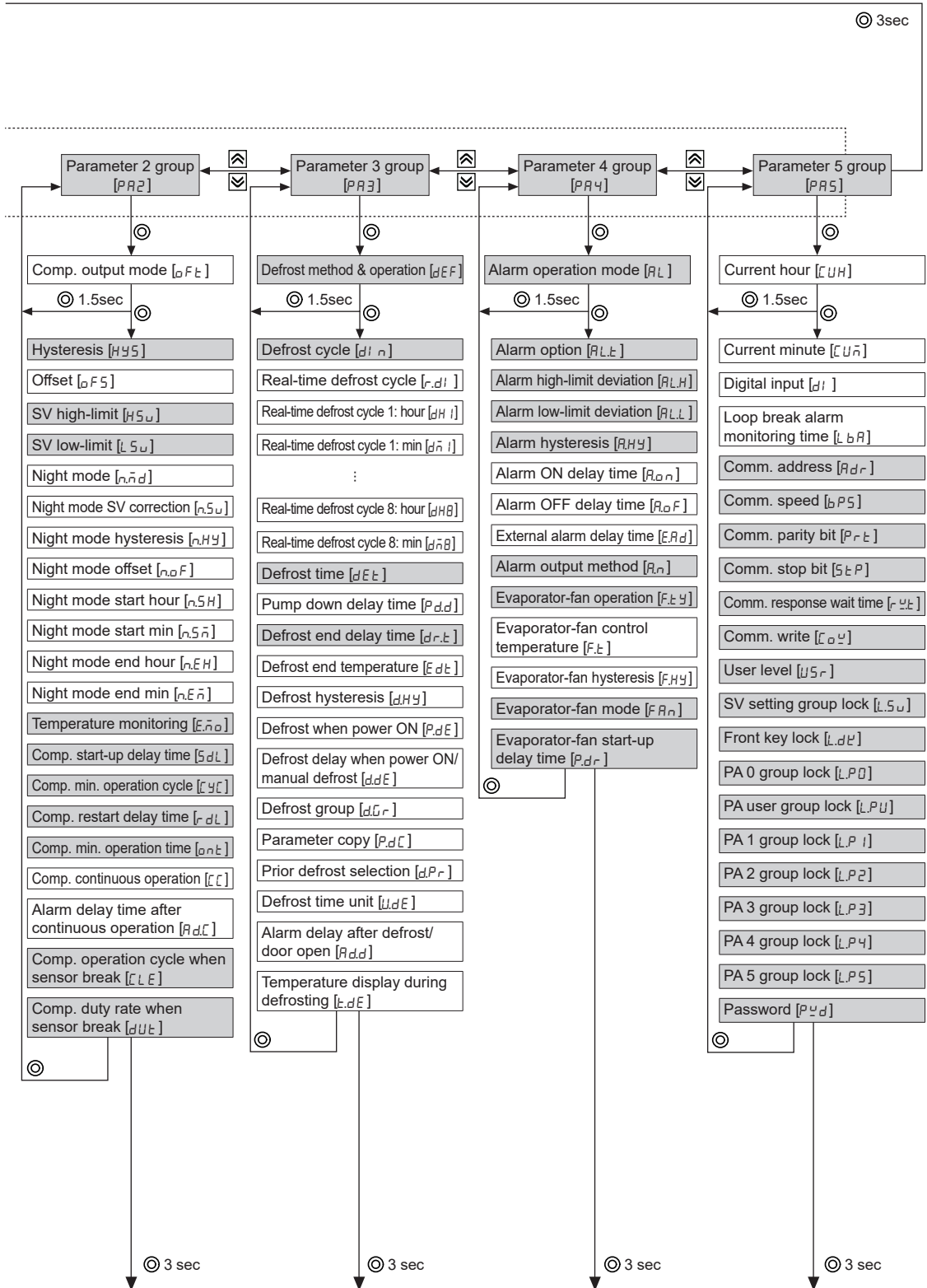

- SENSORS
- CONTROLLERS
- MOTION DEVICES
- SOFTWARE
- (J) Temperature Controllers
- (K) SSRs
- (L) Power Controllers
- (M) Counters
- (N) Timers
- (O) Digital Panel Meters
- (P) Indicators
- (Q) Converters
- (R) Digital Display Units
- (S) Sensor Controllers
- (T) Switching Mode Power Supplies
- (U) Recorders
- (V) HMIs
- (W) Panel PC
- (X) Field Network Devices

TF3 Series

Parameter 1 Group

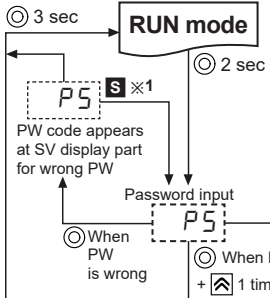

- ※1. **S**: Press any key among **◀**, **▶**, **⏎** keys.
- ※After entering setting mode, hold the **⊙** (MODE) key anytime for 3 sec to return to RUN mode.
- ※After entering setting mode, hold the **⊙** (MODE) key anytime for 1.5 sec to go to the concerned group name.
- ※If you press the **⊙** (MODE) key after changing the set value of the parameter the set value will be stored.
- ※ Shaded parameters are for standard-level users, the others are for high-level users. (You can set the user level [U5r] in parameter 5 group.)
- ※ This parameter might not be displayed depending on other parameter settings or model specifications.

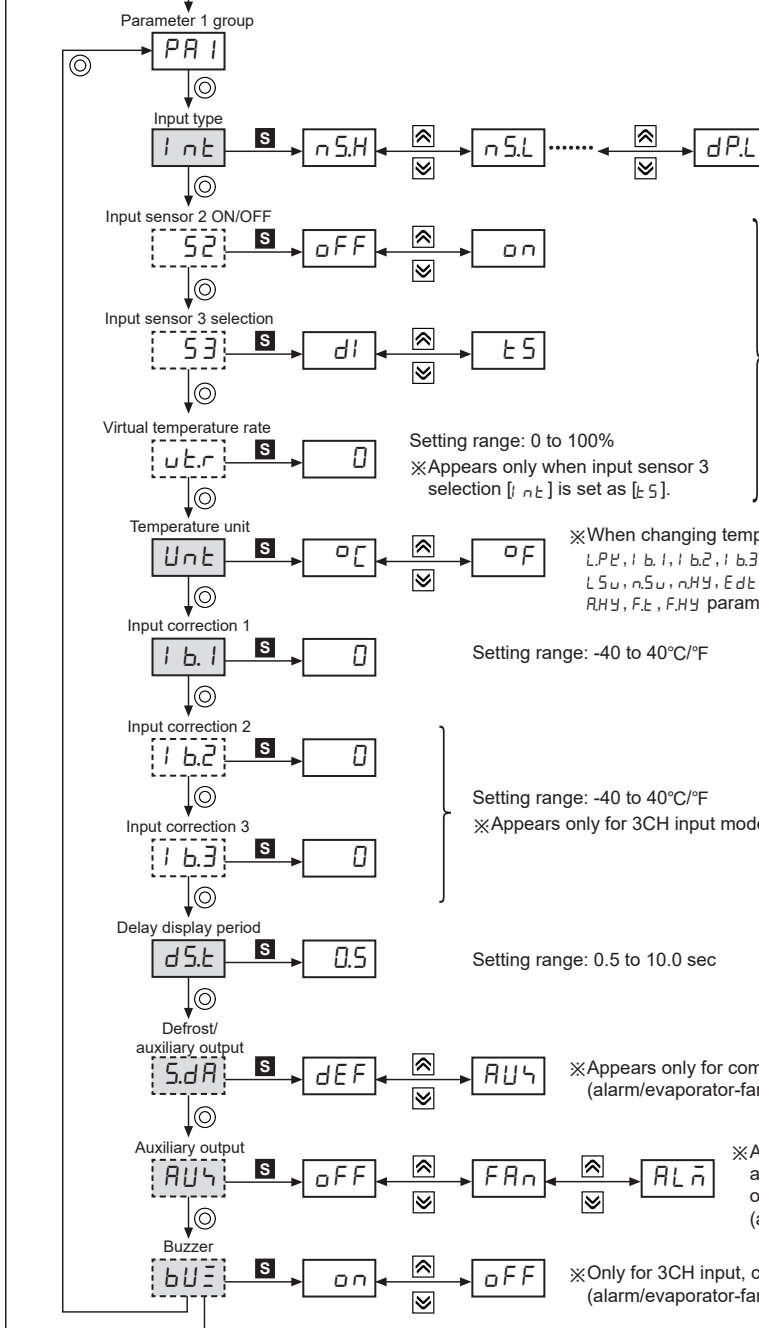

Setting range: Refer to 'Input type and range'.

※When changing input type, *Su, HPF, LPE, 1b1, 1b2, 1b3, HYS, oFS, HSu, L5u, n5u, nHY, EdE, dHY, ALH, ALL, RHY, FE, FHY* parameter values are reset.

※Appears only for 3CH input model.

Setting range: 0 to 100%
 ※Appears only when input sensor 3 selection [i nt] is set as [t5].

※When changing temperature unit, *HPF, LPE, 1b1, 1b2, 1b3, HYS, oFS, HSu, L5u, n5u, nHY, EdE, dHY, ALH, ALL, RHY, FE, FHY* parameter values are reset.

Setting range: -40 to 40°C/°F

Setting range: -40 to 40°C/°F
 ※Appears only for 3CH input model.

Setting range: 0.5 to 10.0 sec

※Appears only for compressor+defrost or auxiliary (alarm/evaporator-fan) output model.

※Appears only for compressor+defrost or auxiliary (alarm/evaporator-fan) output model, compressor+defrost+auxiliary (alarm/evaporator-fan).

※Only for 3CH input, compressor+defrost+auxiliary (alarm/evaporator-fan) output model supports buzzer.

Refrigeration Temperature Controller

Parameter 2 Group

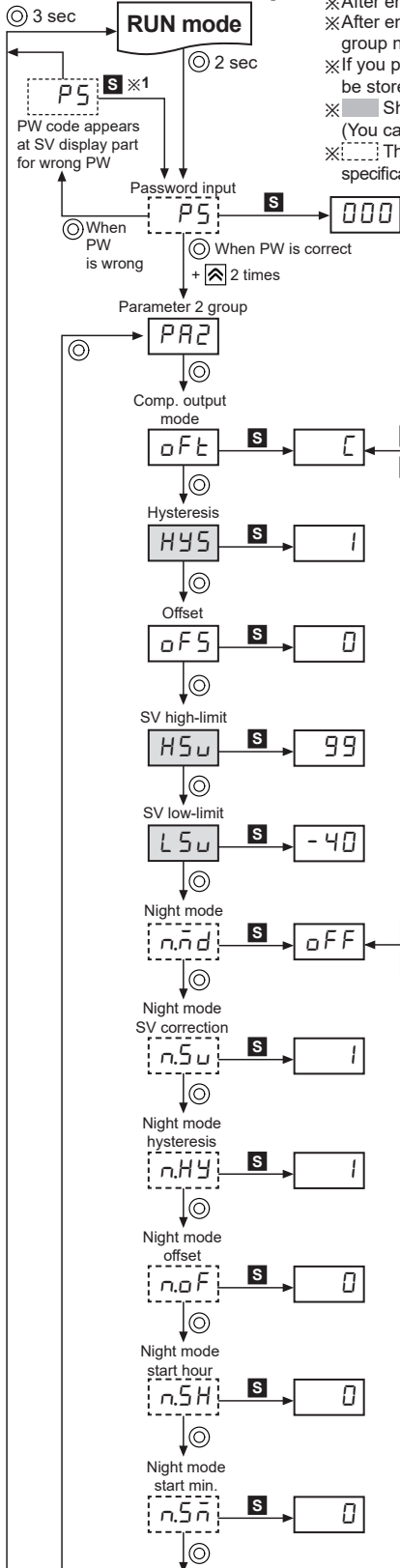

- ※1. **S**: Press any key among , , keys.
- ※After entering setting mode, hold the (MODE) key anytime for 3 sec to return to RUN mode.
- ※After entering setting mode, hold the (MODE) key anytime for 1.5 sec to go to the concerned group name.
- ※If you press the (MODE) key after changing the set value of the parameter the set value will be stored.
- ※ Shaded parameters are for standard-level users, the others are for high-level users. (You can set the user level [U5r] in parameter 5 group.)
- ※ This parameter might not be displayed depending on other parameter settings or model specifications.

※When changing compressor output mode, CL, dU, E parameter values are reset.

Setting range: 1 to 5°C (0.5 to 5.0°C), 2 to 10°F (2.0 to 10.0°F)

Setting range: 0 to 5°C (0.0 to 5.0°C), 0 to 10°F (0.0 to 10.0°F)

Setting range: (L5u + 1 digit) to high-limit value of input type
 ※When changing SV high-limit value and SV > H5u, 5u is reset as H5u.

Setting range: low-limit value of input type to (H5u - 1 digit)
 ※When changing SV low-limit value and SV < L5u, 5u is reset as L5u.

Setting range: -20 to 20°C (-20 to 20.0°C) / -50 to 50°F (-50 to 50.0°F)

Setting range: 1 to 5°C (0.5 to 5.0°C), 2 to 10°F (2.0 to 10.0°F)

Setting range: 0 to 5°C (0.0 to 5.0°C), 0 to 10°F (0.0 to 10.0°F)

Setting range: 0 to 23 hour

Setting range: 0 to 59 min

※Appears for RTC function model or when digital input [di] is set as [nnd] in parameter 5 group.
 ※Does not appear when night mode [nnd] is set as [OFF].

※Appears for RTC function model.
 ※Does not appear when night mode [nnd] is set as [OFF, di].

SENSORS
CONTROLLERS
MOTION DEVICES
SOFTWARE
(J) Temperature Controllers
(K) SSRs
(L) Power Controllers
(M) Counters
(N) Timers
(O) Digital Panel Meters
(P) Indicators
(Q) Converters
(R) Digital Display Units
(S) Sensor Controllers
(T) Switching Mode Power Supplies
(U) Recorders
(V) HMIs
(W) Panel PC
(X) Field Network Devices

TF3 Series

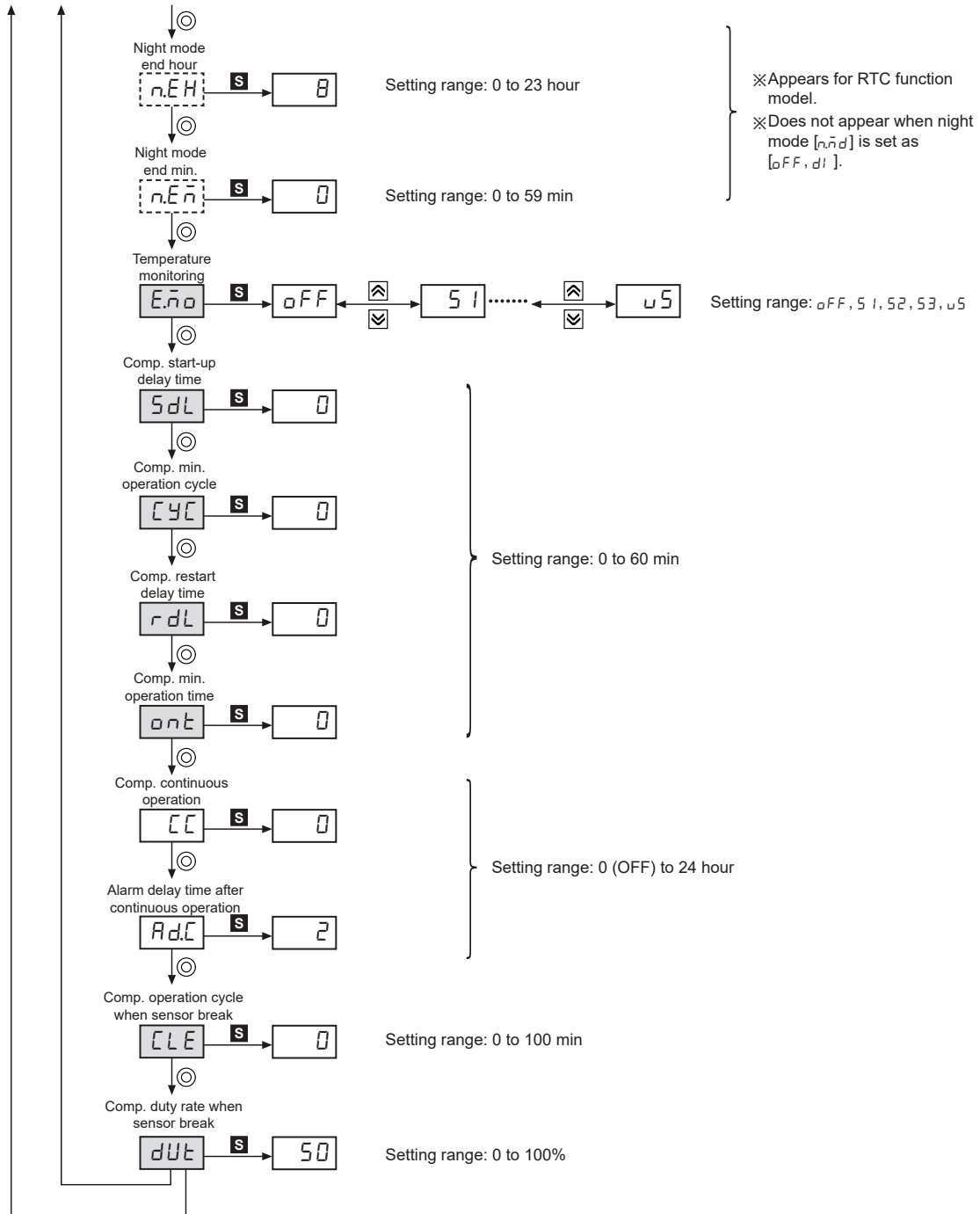

Refrigeration Temperature Controller

Parameter 3 Group

- ※1. **S**: Press any key among \square , \square , \square keys.
- ※After entering setting mode, hold the \odot (MODE) key anytime for 3 sec to return to RUN mode.
- ※After entering setting mode, hold the \odot (MODE) key anytime for 1.5 sec to go to the concerned group name.
- ※If you press the \odot (MODE) key after changing the set value of the parameter the set value will be stored.
- ※ Shaded parameters are for standard-level users, the others are for high-level users. (You can set the user level [U5r] in parameter 5 group.)
- ※ This parameter might not be displayed depending on other parameter settings or model specifications.

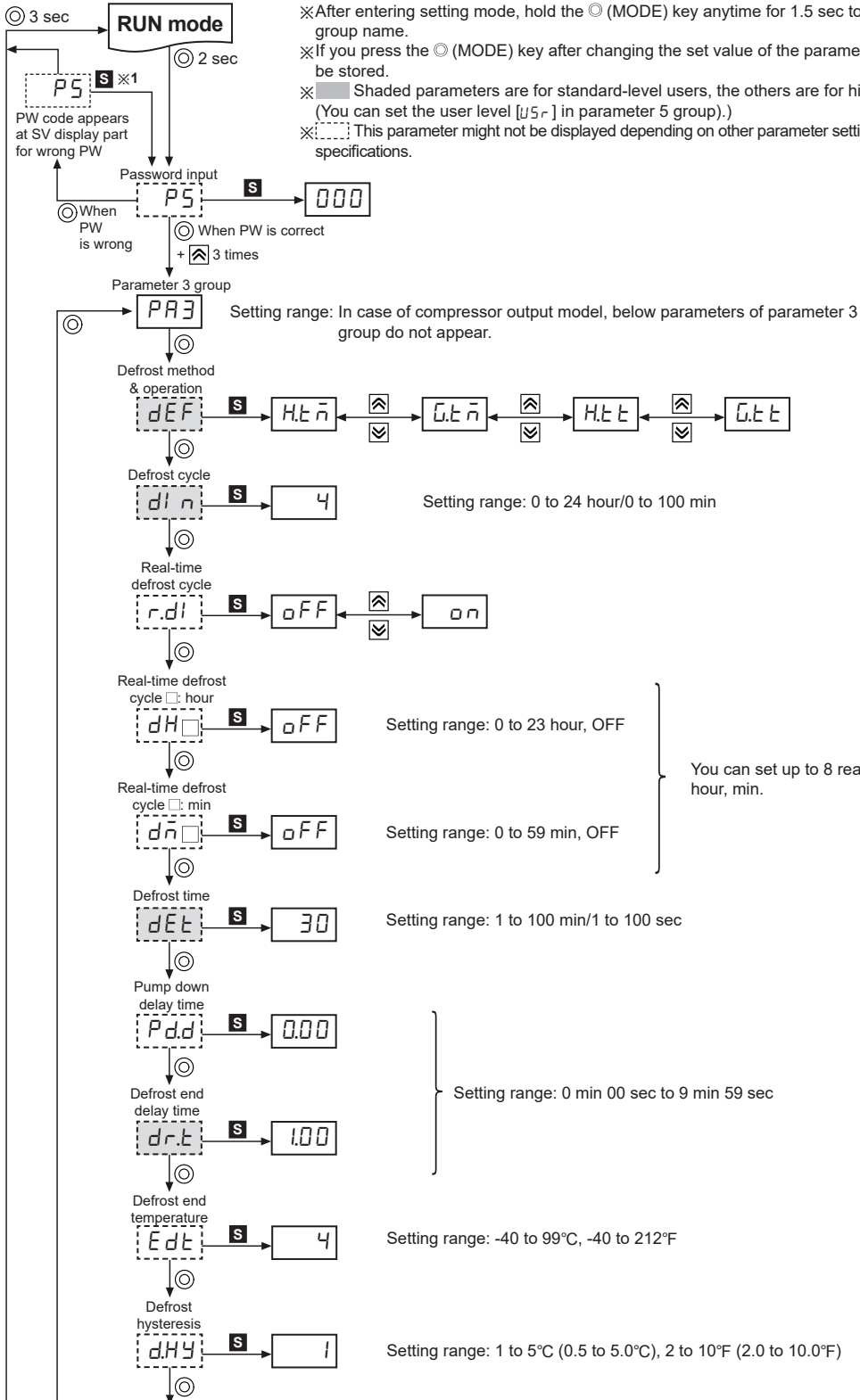

SENSORS
CONTROLLERS
MOTION DEVICES
SOFTWARE

(J) Temperature Controllers
(K) SSRs
(L) Power Controllers
(M) Counters
(N) Timers
(O) Digital Panel Meters
(P) Indicators
(Q) Converters
(R) Digital Display Units
(S) Sensor Controllers
(T) Switching Mode Power Supplies
(U) Recorders
(V) HMIs
(W) Panel PC
(X) Field Network Devices

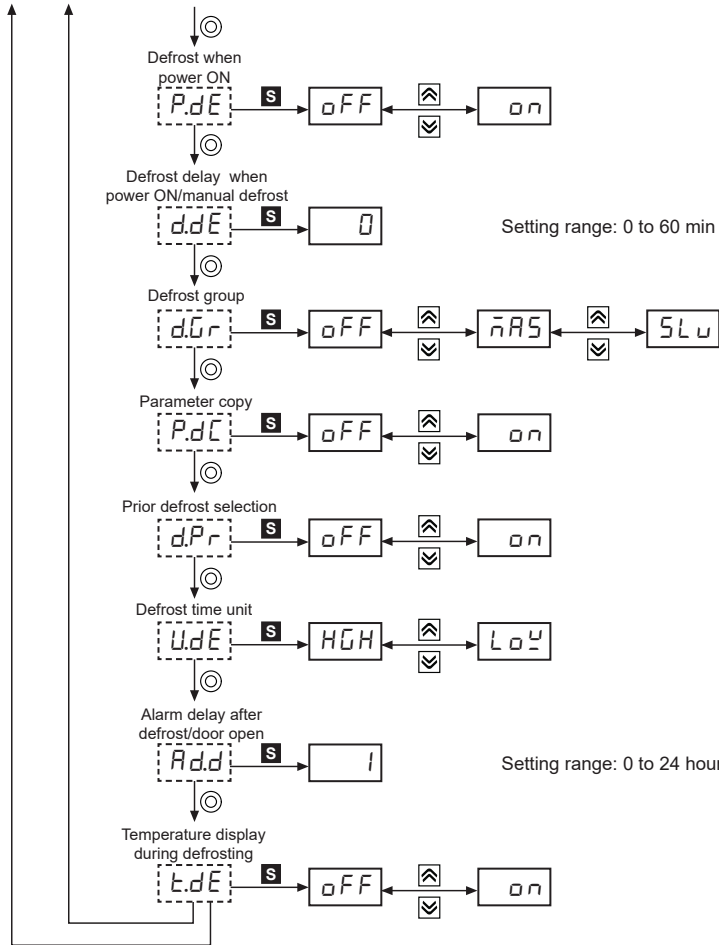

Parameter 4 Group

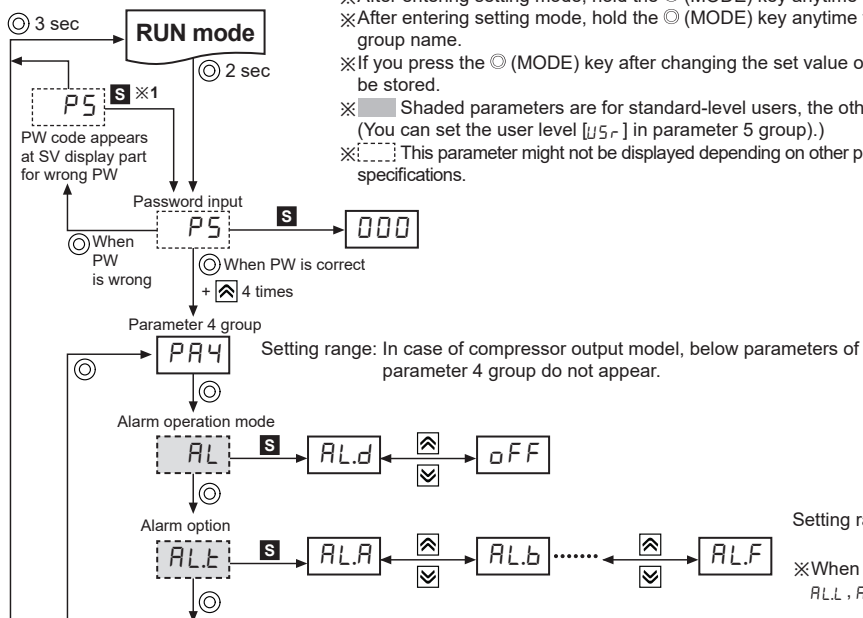

- ※1. **S**: Press any key among keys.
- ※After entering setting mode, hold the (MODE) key anytime for 3 sec to return to RUN mode.
- ※After entering setting mode, hold the (MODE) key anytime for 1.5 sec to go to the concerned group name.
- ※If you press the (MODE) key after changing the set value of the parameter the set value will be stored.
- ※ Shaded parameters are for standard-level users, the others are for high-level users. (You can set the user level [U5r] in parameter 5 group.)
- ※ This parameter might not be displayed depending on other parameter settings or model specifications.

Setting range: AL.A, AL.b, AL.c, AL.d, AL.E, AL.F
 ※When changing alarm option, AL.L, AL.H, AL.Y parameter values are reset.

Refrigeration Temperature Controller

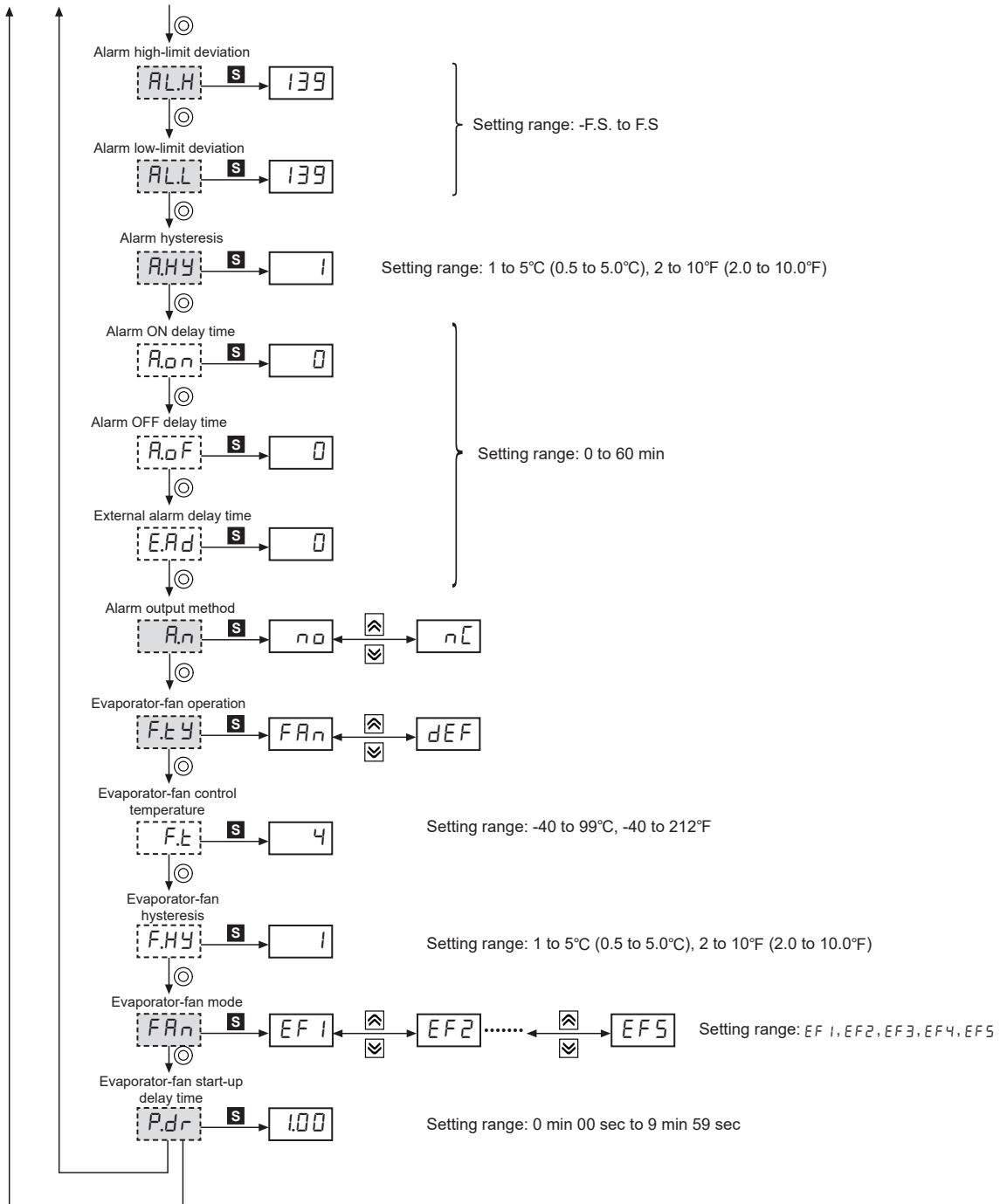

SENSORS
CONTROLLERS
MOTION DEVICES
SOFTWARE

(J) Temperature Controllers
(K) SSRs
(L) Power Controllers
(M) Counters
(N) Timers
(O) Digital Panel Meters
(P) Indicators
(Q) Converters
(R) Digital Display Units
(S) Sensor Controllers
(T) Switching Mode Power Supplies
(U) Recorders
(V) HMIs
(W) Panel PC
(X) Field Network Devices

Parameter 5 Group

- ※1. **S**: Press any key among \square , \square , \square keys.
- ※After entering setting mode, hold the \odot (MODE) key anytime for 3 sec to return to RUN mode.
- ※After entering setting mode, hold the \odot (MODE) key anytime for 1.5 sec to go to the concerned group name.
- ※If you press the \odot (MODE) key after changing the set value of the parameter the set value will be stored.
- ※ Shaded parameters are for standard-level users, the others are for high-level users. (You can set the user level [U5r] in parameter 5 group.)
- ※ This parameter might not be displayed depending on other parameter settings or model specifications.

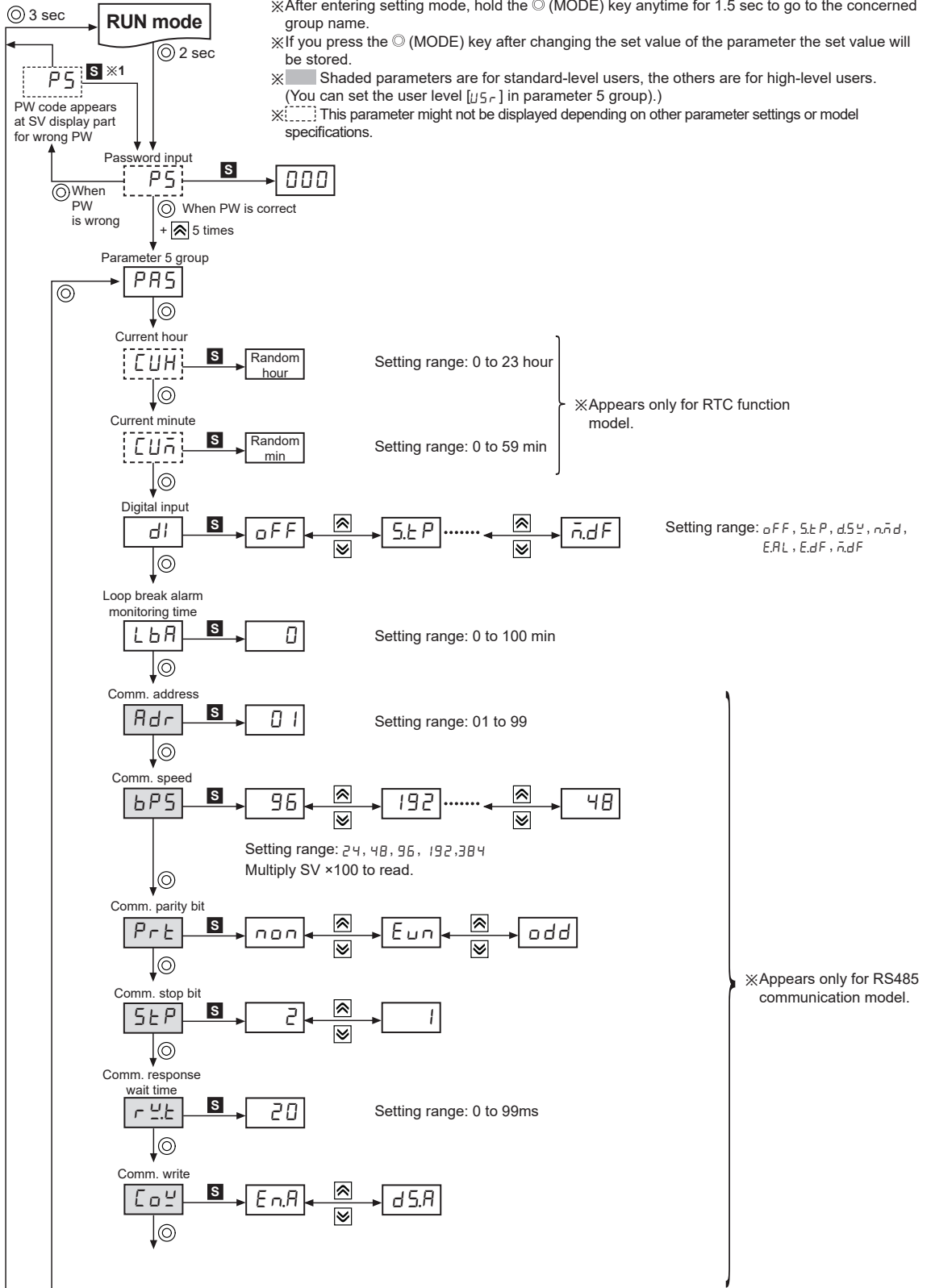

Refrigeration Temperature Controller

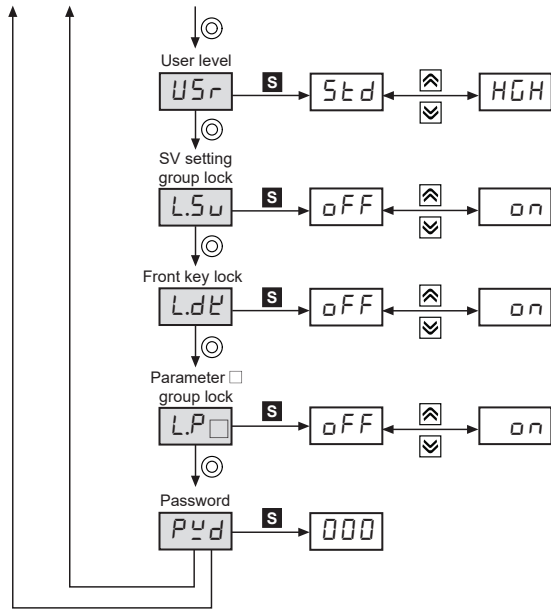

■ Parameter Reset

Hold $\left[\text{Up} \right] + \left[\text{Down} \right] + \left[\text{Enter} \right]$ keys for 5 sec to reset all parameters in memory to default value.

Set [*ni*] parameter to [*YE5*] to reset all parameters.

In case password function is ON, it is required to enter valid password to reset parameters.

Password is also reset.

SENSORS
CONTROLLERS
MOTION DEVICES
SOFTWARE

(J) Temperature Controllers
(K) SSRs
(L) Power Controllers
(M) Counters
(N) Timers
(O) Digital Panel Meters
(P) Indicators
(Q) Converters
(R) Digital Display Units
(S) Sensor Controllers
(T) Switching Mode Power Supplies
(U) Recorders
(V) HMIs
(W) Panel PC
(X) Field Network Devices

TF3 Series

■ Factory Default

● SV setting [5U]

Parameter	Factory default
5u	0

● Parameter 0 group

Parameter	Factory default
dP _t	51
n _o t	—

● Parameter 1 group [PAR 1]

Parameter	Factory default	Parameter	Factory default	Parameter	Factory default
l n _t	n5H	U n _t	°C	RU ₄	oFF
S2	oFF	i b _□	0	bU _Ξ	on
S3	d!	dS _t	0.5		
u _t r	0	S _d R	dEF		

● Parameter 2 group [PAR 2]

Parameter	Factory default	Parameter	Factory default	Parameter	Factory default	Parameter	Factory default
oF _t	ℓ	nS _u	1	nE _ñ	0	ℓℓ	0
HYS	1	nHY	1	E _ñ o	oFF	Rdℓ	2
oFS	0	n _o F	0	S _d ℓ	0	ℓℓE	0
H5 _u	99	nSH	0	ℓYℓ	0	dU _t	50
LS _u	-40	n _t ñ	0	r _d ℓ	0		
n _ñ d	oFF	nEH	8	o _n t	0		

● Parameter 3 group [PAR 3]

Parameter	Factory default	Parameter	Factory default	Parameter	Factory default	Parameter	Factory default
dEF	H _t ñ	dE _t	30	P _d E	oFF	U _d E	HGH
d _i n	4	P _d d	0.00	d _d E	0	R _d d	1
r _d i	oFF	d _r t	100	dG _r	oFF	t _d E	oFF
dH _□	oFF	E _d t	4	P _d ℓ	oFF		
d _ñ □	oFF	dHY	1	dP _r	oFF		

● Parameter 4 group [PAR 4]

Parameter	Factory default	Parameter	Factory default	Parameter	Factory default	Parameter	Factory default
RL	RL _d	RHY	1	R _n	n _o	FR _n	EF 1
RL _t	RL _R	R _o n	0	F _t Y	FR _n	P _d r	1.00
RL _H	139	R _o F	0	F _t	4		
RL _L	139	ER _d	0	F _H Y	1		

● Parameter 5 group [PAR 5]

Parameter	Factory default	Parameter	Factory default	Parameter	Factory default	Parameter	Factory default
ℓUH	Random hour	R _d r	01	r _Y t	20	ℓ _d t	oFF
ℓU _ñ	Random min	bPS	96	ℓ _o Y	E _n R	ℓP _□	oFF
d!	oFF	P _r t	n _o n	US _r	S _t d	P _Y d	0.00
ℓb _R	0	S _t P	2	LS _u	oFF		

Refrigeration Temperature Controller

■ Alarm (Except 1CH, Compressor Output Model: TF31-1□□)

Set both alarm operation and alarm option by combining. Alarm function is available for compressor+defrost or auxiliary (alarm/evaporator-fan) output model (TF3□-2□□-□). Also defrost/auxiliary output [5dR] of parameter 1 group should be set as auxiliary [RUV], and auxiliary output [RUV] should be set as alarm [RLn]. In case of compressor+defrost+auxiliary (alarm/evaporator-fan) output model (TF3□-3□□-□), auxiliary output [RUV] of parameter 1 group should be set as alarm [RLn].

◎ Alarm operation [RL]

Mode	Name	Alarm operation	Description
oFF	—	—	No alarm output.
RLd	Deviation high, low-limit alarm	<p>High-limit deviation [RLH]: Set as 20, Low-limit deviation [RLL]: Set as 10</p>	If deviation between present value (PV) and setting value (SV) is higher than high-limit or low-limit deviation SV, alarm output turns ON.

※ H: alarm output hysteresis [RHV]

◎ Alarm option [RLt]

Mode	Name	Description
RLR	Standard alarm	If it is an alarm condition, alarm output is ON. If it is a clear alarm condition, alarm output is OFF.
RLb	Alarm latch ^{※1}	If it is an alarm condition, alarm output is ON and maintains ON status.
RLC	Standby sequence 1	First alarm condition is ignored and from second alarm condition, standard alarm operates. When power is supplied and it is an alarm condition, this first alarm condition is ignored and from the second alarm condition, standard alarm operates.
RLd	Alarm latch and standby sequence 1	If it is an alarm condition, it operates both alarm latch and standby sequence. When power is supplied and it is an alarm condition, this first alarm condition is ignored and from the second alarm condition, alarm latch operates.
RL E	Standby sequence 2	First alarm condition is ignored and from second alarm condition, standard alarm operates. When re-applied standby sequence ^{※2} and if it is alarm condition, alarm output does not turn ON. After clearing alarm condition, standard alarm operates.
RL F	Alarm latch and standby sequence 2	Basic operation is same as alarm latch and standby sequence 1. It operates not only by power ON/OFF, but also alarm set value, or alarm option changing. When re-applied standby sequence ^{※2} and if it is alarm condition, alarm output does not turn ON. After clearing alarm condition, alarm latch operates.

※1: To clear alarm, turn OFF the power (also digital input [dI] is set as RUN/STOP [5tP] and input is ON for pausing compressor output) or press the front [K] key once. (press twice when buzzer is set)

※2: Condition of re-applied standby sequence for standby sequence: Power ON, changing temperature, alarm settings, switching STOP mode to RUN mode (also digital input [dI] is set as RUN/STOP [5tP] and input turns OFF from ON for operation mode by releasing pause compressor output)

SENSORS
CONTROLLERS
MOTION DEVICES
SOFTWARE
(J) Temperature Controllers
(K) SSRs
(L) Power Controllers
(M) Counters
(N) Timers
(O) Digital Panel Meters
(P) Indicators
(Q) Converters
(R) Digital Display Units
(S) Sensor Controllers
(T) Switching Mode Power Supplies
(U) Recorders
(V) HMIs
(W) Panel PC
(X) Field Network Devices

■ Functions

◎ Compressor protection

This function is for preventing compressor from life cycle shortening or malfunction by overload and frequent ON/OFF of compressor. As compressor protection settings, when compressor output does not ON, the front compressor (COMP) output indicator (green) is flashing.

● Compressor start-up delay time [5dL]

If power turns ON instantly from break-down or power OFF, it delays start-up during the set time of compressor. Setting range: 0 to 60 (min)

● Compressor restart delay time [rdL]

To prevent frequent compressor ON/OFF, set compressor ON time after compressor turns OFF. Setting range: 0 to 60 (min)

● Compressor min. operation time [onL], compressor min. operation cycle [cyc]

To prevent frequent compressor ON/OFF, set min. operation time and min. operation cycle. Setting range of compressor min. operation time: 0 to 60 (min), Setting range of compressor min. operation cycle: 0 to 60 (min)

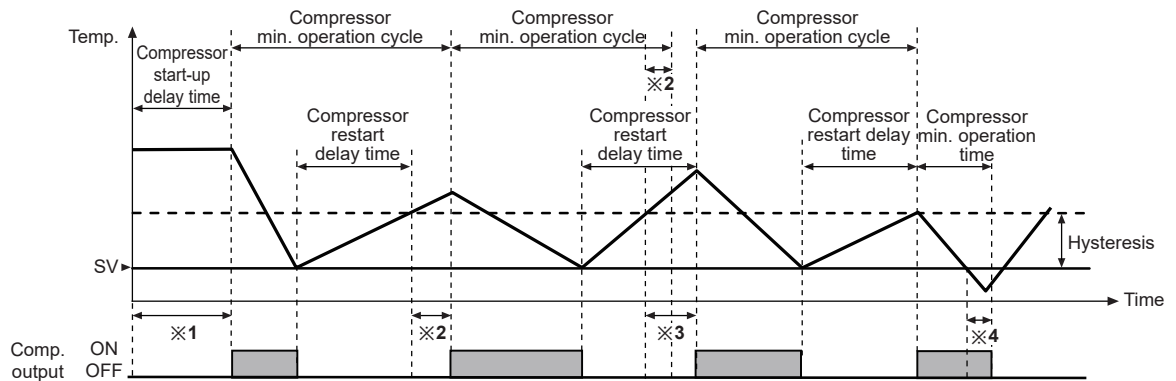

※1: When starting compressor, if present value (PV) is out of hysteresis range, compressor output does not turn ON and the compressor (COMP) output indicator is flashing during compressor start-up delay time.

※2: When compressor delay is completed and it is within compressor min. operation cycle, compressor output does not turn ON and the compressor (COMP) output indicator is flashing. (The latest one has priority between compressor restart delay time and compressor min. operation cycle.)

※3: When present value (PV) is out of hysteresis, compressor output does not turn ON and the compressor (COMP) output indicator is flashing during compressor restart delay time.

※4: If present value (PV) is below the SV, compressor output maintains ON status during compressor min. operation time. After compressor min. operation time, it turns OFF.

※If compressor output does not turn ON due to compressor output condition or parameter settings for compressor protection, the compressor (COMP) output indicator is flashing.

★For more information about parameters for compressor prevention, refer to user manual.

◎ Compressor control when sensor break

If normal temperature control is impossible due to sensor break, it controls compressor output by the set operation cycle and duty ratio to protect control object. Until error is cleared, operation cycle and duty ratio are applied repeatedly. When error is cleared, the compressor operates after completing the currently applied operation cycle and compressor restart delay time.

● Compressor operation cycle when sensor break [cLE]

Set compressor operation cycle when sensor break. Set as [c] and compressor output turns OFF when sensor break. Setting range: 0 to 100 (min)

● Compressor duty ratio when sensor break [dUL]

Set compressor ON duty ratio when sensor break. Setting range: 0 to 100 (%)

E.g.) When compressor operation cycle when sensor break [cLE] is set as 60 min and compressor duty ratio when sensor break [dUL] is set as 50%, compressor output has 60 min cycle and turns ON for 30 min and turns OFF for 30 min.

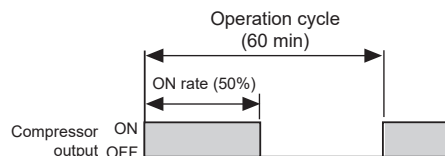

Refrigeration Temperature Controller

☉ Defrost control (except 1CH, compressor output model: TF31-1□□)

When operating a compressor for a long time, an evaporator and a freezer are freezing and thermal efficiency of compressor is decreased. For increasing thermal efficiency, defrost operation helps to remove frost or ice around of evaporator.

Set defrost cycle, time, and end temperature, etc to operate defrost (heater/hot-gas defrost).

The front defrost (DEF) output indicator (green) turns ON during defrost output and it flashes during defrost delay operation.

In case of compressor+defrost or auxiliary (alarm/evaporator-fan) output model (TF3□-2□□-□), defrost operation is available when defrost/auxiliary output [5.dR] of parameter 1 group is set as defrost [dEF].

● Defrost method and operation [dEF]

Parameter	Defrost method	Defrost operation
H.t.n	Heater defrost	Operates during the set defrost cycle/time
G.t.n	Hot-gas defrost	
H.t.t	heater defrost	Operates when PV is lower than defrost end temperature during the set defrost cycle/time (only for 3CH input model (TF33-□□□-□))
G.t.t	Hot-gas defrost	

● Defrost cycle [dI n], defrost time [dEt]

Set defrost cycle and time to operate defrost at every set cycle and during the set time.

Defrost cycle setting range: 0 to 24 (hour)/0 to 100 (min)

Defrost time setting range: 1 to 100 (min/sec)

※Compressor operation during defrost is varied by defrost method. In case of heater defrost, compressor output turns OFF, and in case of hot-gas defrost, compressor output turns ON. Evaporator-fan operation is varied by evaporator-fan operation mode setting.

※In case of RTC function model (TF33-3□□-R/A), defrost operates at every specific time. Set real-time defrost cycle [r.dI] of parameter 3 group as [o.n] and 8 real-time defrost times are available to set.

● Defrost end temperature [Edt], Defrost hysteresis [dHy] (only for 3CH input model: TF33-□□□-□)

Set defrost end temperature and defrost hysteresis from input sensor 2 (defrost temperature). When the measured temperature of defrost sensor is same as the set defrost end temperature, defrost operation is stopped. It is available when input sensor 2 ON/OFF [5P] is set as [o.n] and defrost method and operation [dEF] is set as [H.t.t] or [G.t.t].

Defrost end temperature setting range: -40 to 99 (°C) / -40 to 212 (°F)

Defrost hysteresis setting range: 1 to 5 (1.0 to 5.0) (°C) / 2 to 10 (°F)

● Manual defrost

Execute defrost manually regardless of the set defrost cycle which consists of defrost method and operation setting. Hold the front key over 3 sec or, turn ON the digital input when digital input [dI] of parameter 5 group is set as [n.dF] to operate defrost during the set defrost time.

The front defrost (DEF) output indicator turns ON for 2 sec and turns OFF for 1 sec during manual defrost. Hold the front key over 3 sec or turn OFF the digital input during manual defrost, and the set defrost cycle re-starts.

● Defrost synchronization

(only for synchronize defrost function model: TF33-□□A-S, RS485 communication model: TF33-□□A-T/A)

When connecting over 2 units of TF3, defrost and compressor operation is able to synchronize via synchronize terminal/RS485 communication.

It is available for synchronize defrost function model (TF33-□□A-S), or RS485 communication model (TF33-□□A-T/A). [Setting Order]

1. Connect each other synchronize terminals or RS485 communication terminals of the units which are synchronized for defrost.
2. Set defrost cycle [dI n] same as among the units. (if error occurs, defrost cycle is the setting of each unit)
3. Set defrost group [dGr] as 1 master unit [nRS] and slave unit (s) (up to 5 units) [SLR].
4. According to defrost operation of Master, the defrost operation of slave (s) executes. (when changing the defrost parameters of master, defrost operations of slave (s) are also changed forcibly as same as the defrost operation of master via connected terminals. The defrost parameters of slave (s) are not changed.)

※Defrost operation by real-time defrost cycle is not able to synchronize.

※Defrost operation of master is prior to the compressor operation of slave.

★For more information about parameters for defrost operations, refer to user manual.

SENSORS

CONTROLLERS

MOTION DEVICES

SOFTWARE

(J)
Temperature
Controllers

(K)
SSRs

(L)
Power
Controllers

(M)
Counters

(N)
Timers

(O)
Digital
Panel Meters

(P)
Indicators

(Q)
Converters

(R)
Digital
Display Units

(S)
Sensor
Controllers

(T)
Switching
Mode Power
Supplies

(U)
Recorders

(V)
HMIs

(W)
Panel PC

(X)
Field Network
Devices

TF3 Series

◎ Evaporator-fan control (except 1CH, compressor output model: TF31-1□□)

To improve the efficiency of cooling, install and control evaporator-fan at evaporator.

It is available for compressor+defrost or auxiliary (alarm/evaporator-fan) output model (TF3□-2□□-□). Also defrost/auxiliary output [5dR] of parameter 1 group should be set as auxiliary [RUY], and auxiliary output [RUY] should be set evaporator-fan [FRN].

It is available for compressor+defrost+auxiliary (alarm/evaporator-fan) output model (TF3□-3□□-□). Also, auxiliary output [RUY] of parameter 1 group should be set as evaporator-fan [FRN].

●Evaporator-fan operation [FUY]

Evaporator-fan operates by two control methods; [dEF] controls evaporator-fan by measured temperature from defrost sensor or [FRN] controls evaporator-fan by compressor/defrost operation.

●Evaporator-fan control temperature [FUY] and hysteresis [FHY]

When evaporator-fan operation [FUY] is set as [dEF] controls (evaporator-fan is controlled by measured temperature from defrost sensor), and the temperature of defrost sensor is same as evaporator-fan control temperature [FUY], evaporator-fan output turns OFF. Set evaporator-fan control temperature [FUY] and evaporator-fan control hysteresis [FHY].

Evaporator-fan control temperature setting range: -40 to 99 (°C), -40 to 212 (°F)

Evaporator-fan control hysteresis setting range: 1 to 5 (0.5 to 5.0) (°C), 2 to 10 (°F)

●Evaporator-fan operation mode [FRN] and evaporator-fan start-up delay time [Pdr]

When evaporator-fan operation [FUY] is set as [FRN] for control by compressor/defrost operation, it is available to set [FRN] for evaporator-fan operation mode for compressor/defrost operation.

Parameter	Operation method
EF1	When compressor operates, evaporator-fan also operates. When compressor operation is finished, evaporator-fan also operation turns OFF. (except compressor operation for hot gas defrost)
EF2	When compressor operates, evaporator-fan operates after the set evaporator-fan start-up delay time. When compressor operation is finished, evaporator-fan operation turns OFF. (regardless of defroster operation)
EF3	When power turns ON, evaporator-fan operates. When defroster operates, evaporator-fan stops. (regardless of compressor operation)
EF4	Evaporator-fan operates only when operating compressor or defrost. Evaporator-fan stops when compressor and defroster stops. (for above zero temperature control)
EF5	Evaporator-fan operates from power ON to power OFF. (regardless of defroster operation of freezer. When door is open (digital input [di] is set as RUN/STOP [5EP] or door switch [d5U]), evaporator-fan stops.

If evaporator temperature is increased by defrost operation, warm air may flow into cooling system by evaporator-fan operation. Set evaporator-fan start-up delay time [Pdr] to prevent warm air inflow, and it may increase cooling efficiency. Evaporator-fan start-up delay time setting range: 0.00 to 9.59 (0 min 00 sec to 9 min 59 sec)

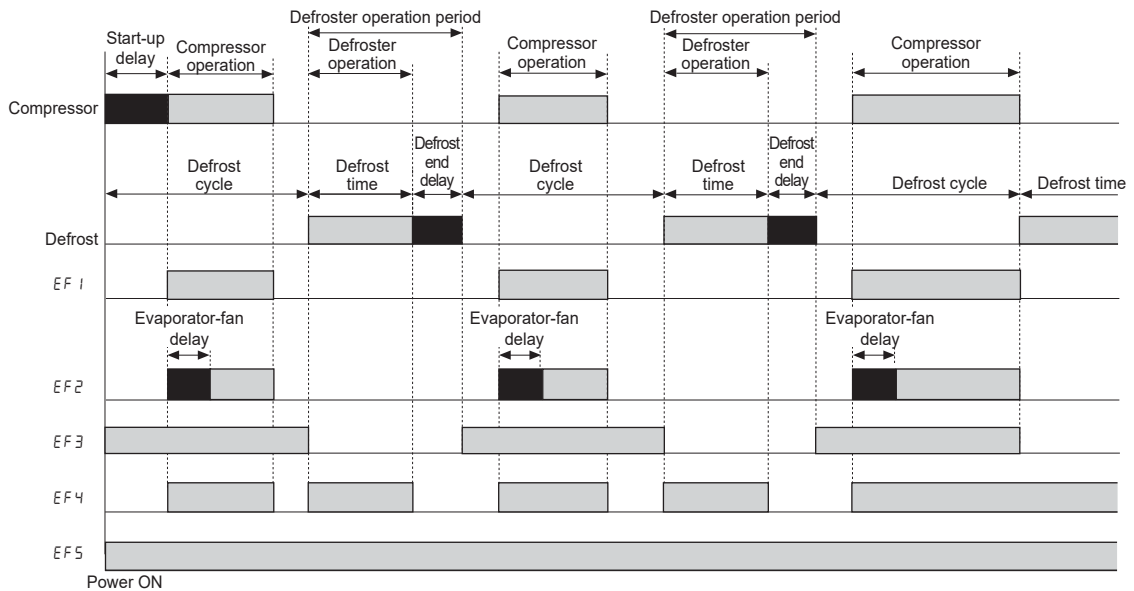

※■: Output does not turn ON but the dedicated indicator flashes at the delay period (compressor, defrost, evaporator-fan).

★For more information about parameters for evaporator-fan control, refer to user manual.

Refrigeration Temperature Controller

Ⓞ Digital input [dI]

※Digital input is available only for 3CH input model (TF33-□□□-□). Also input sensor 3 selection [53] should be set as digital input [dI].

Parameter		Function
OFF	oFF	No digital input
RUN/STOP	StP	Pauses compressor output. All output indicators turn OFF. When digital input is OFF, it controls normally after compressor restart delay time.
Door switch	dSv	By connecting freezer door switch and digital input contact, it controls compressor/defrost/evaporator-fan according to the door status. - Digital input ON (door open): Compressor, defrost, evaporator-fan output turns OFF - Digital input OFF (door close): After 1 min, it returns the previous status of door open. (not applied compressor protection operations) Alarm occurs after the time of alarm delay after defrost/door open [Rd] of parameter 3 group. When operating compressor continuously, compressor start-up time is extended as long as the door open time.
Night mode ON/OFF	nnd	When digital input turns ON, night mode is active.
External alarm ^{※1}	ERL	When digital input turns ON, alarm output turns ON forcibly. (except alarm is ON) When external alarm delay time [ERd] of parameter 4 group is set, alarm turns ON after the set time.
Defrost ON/OFF ^{※1}	EdF	When digital input turns ON and it is defrost operation condition, defrost output turns ON. Even though it is defrost operation condition, if digital input turns OFF, defrost output turns OFF also.
Manual defrost ^{※1}	ndF	When digital input turns ON, it executes manual defrost.

※1: Except 1CH, compressor output model (TF31-1□□).

Ⓞ Virtual temperature rate [vtr] (only for 3CH input model: TF33-□□□-□)

In case of 3CH input model (TF33-□□□-□), input sensor 3 selection [53] of parameter 1 group is set as outlet temperature [t5]. You can set virtual temperature rate.

If the temperature of inlet and outlet is significantly different at freezer, virtual temperature helps to control temperature efficiently.

Virtual temperature is designated by the rate of input sensor 1 (inlet temperature) and input sensor 3 (outlet temperature). There is virtual temperature calculation formula.

$$\text{Virtual temperature (PV)} = \frac{\{[100 - \text{virtual temperature rate}] \times \text{input sensor 1 temperature}\} + [\text{virtual temperature rate} \times \text{input sensor 2 temperature}]}{100}$$

If virtual temperature rate [vtr] is set as [0], virtual temperature (PV) = input sensor 1.

If virtual temperature rate [vtr] is set as [100], virtual temperature (PV) = input sensor 3

E.g.) If inlet temperature of input sensor 1 is 0°C, and outlet temperature of input sensor 3 is 10°C, set virtual temperature rate [vtr] as [50] and virtual temperature is 5°C to control temperature.

$$5 = \frac{\{[100 - 50] \times 0\} + [50 \times 10]}{100}$$

Setting range of virtual temperature rate: 0 to 100 (%)

Ⓞ Display selection [dPE] (only for 3CH input model: TF33-□□□-□)

You can select input sensor to display at present value (PV) display component in RUN mode.

Parameter	Description
51	Displays PV of input sensor 1 (inlet temperature).
52	Displays PV of input sensor 2 (defrost temperature).
53	Displays PV of input sensor 3 (outlet temperature).
v5	Displays virtual temperature.

Ⓞ Parameter mask

This function is able to hide unnecessary parameters to user environment or less frequently used parameters in parameter group. You can set this in the comprehensive device management program (DAQmaster).

Masked parameters are only not displayed. The setting value of masked parameters are applied.

For more information, refer to DAQMaster user manual.

Visit our web site (www.autonics.com) to download DAQmaster program and the user manual.

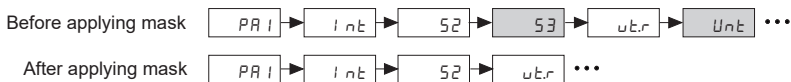

The above is masking input sensor 3 selection [53], temperature unit [Unit] of parameter 1 group for 3CH input model (TF33-□□□-□).

SENSORS
CONTROLLERS
MOTION DEVICES
SOFTWARE
(J) Temperature Controllers
(K) SSRs
(L) Power Controllers
(M) Counters
(N) Timers
(O) Digital Panel Meters
(P) Indicators
(Q) Converters
(R) Digital Display Units
(S) Sensor Controllers
(T) Switching Mode Power Supplies
(U) Recorders
(V) HMIs
(W) Panel PC
(X) Field Network Devices

TF3 Series

◎ Parameter user group [PAU]

This function is able to set the frequently used parameters to the user parameter group. You can quickly and easily set parameter settings. User parameter group can have up to 30 parameters in the comprehensive device management program (DAQMaster).

For more information, refer to the DAQMaster user manual.

Visit our web site (www.autonics.com) to download the DAQMaster program and the user manual.

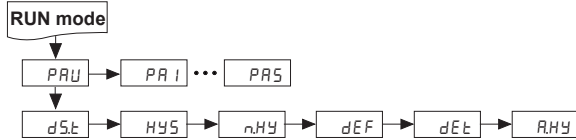

The above is setting user parameter group in the DAQMaster with delay display period [d5.t] of parameter 1 group, hysteresis [HY5], night mode hysteresis [n.HY] of parameter 2 group, defrost method [dEF], defrost time [dEt] of parameter 3 group, alarm output hysteresis [RH.Y] of parameter 4 group.

◎ Communication output

It is for parameter setting and monitoring via external devices (PC, PLC, etc.).

● Interface

Comm. protocol	Modbus RTU	Comm. speed	2400, 4800, 9600, 19200, 38400 bps
Connection type	RS485	Comm. response wait time	5 to 99 ms
Application standard	Compliance with EIA RS485	Start bit	1-bit (fixed)
Max. connection	31 units (address: 01 to 99)	Data bit	8-bit (fixed)
Synchronous method	Asynchronous	Parity bit	None, Odd, Even
Comm. method	Two-wire half duplex	Stop bit	1-bit, 2-bit
Comm. distance	Max. 800m		

※It is not allowed to set overlapping communication address at the same communication line.

Use twisted pair wire for RS485 communication.

● Application of system organization

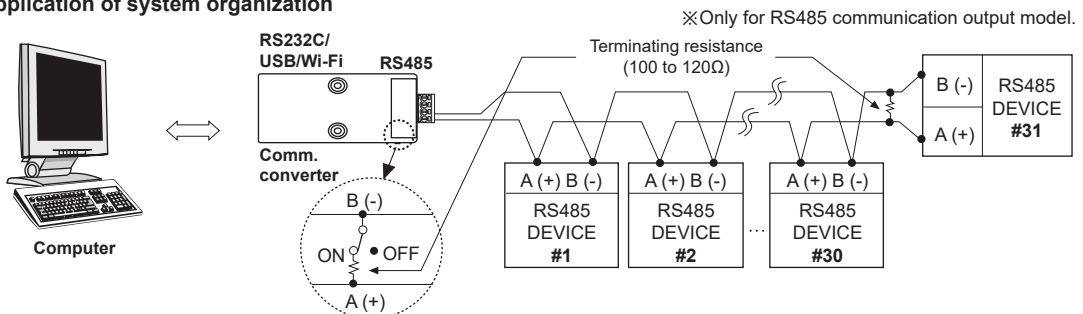

※It is recommended to use Autonics communication converter; SCM-WF48 (Wi-Fi to RS485·USB wireless communication converter, sold separately), SCM-US48I (USB to RS485 converter, sold separately), SCM-38I (RS232C to RS485 converter, sold separately).

Please use twisted pair wire, which is suitable for RS485 communication, for SCM-WF48, SCM-US48I and SCM-38I.

■ Error Display

Flashing in turn	Description	Troubleshooting
$E_r \square^{*1} \times 2 \leftrightarrow \square P_n$	When input sensor is break or sensor is disconnected.	Check input sensor status.
$E_r \square^{*1} \leftrightarrow L L L$	If the measured temperature of the dedicated sensor is lower than low-limit temperature among temperature setting range.	It clears when input is within the display range.
$E_r \square^{*1} \leftrightarrow H H H$	If the measured temperature of the dedicated sensor is higher than high-limit temperature among temperature setting range.	
$E_r r \leftrightarrow L b R$	Even though input sensor is normal, freezer temperature does not change over 1.0°C (1.8°F) during loop break alarm monitoring time [L b R].	Check the compressor and hold the $\boxtimes + \boxtimes$ key at the same time for 3 sec. It clears when input is within the adequate range.

※1: \square indicates input sensor number of error display priority which occurs error.

Error display priority: $E_r 1$ (input sensor 1) $\rightarrow E_r 2$ (input sensor 2) $\rightarrow E_r 3$ (input sensor 3) \rightarrow

$E_r U$ (virtual temperature) $\rightarrow E_r r$

※2: $E_r U$ (virtual temperature) is not applicable.

Refrigeration Temperature Controller

■ Proper Usage

◎ Cautions during use

- Follow instructions in 'Cautions during use'. Otherwise, It may cause unexpected accidents.
- Check the polarity of the terminals before wiring the temperature sensor.
For RTD temperature sensor, wire it as 3-wire type, using cables in same thickness and length.
For thermocouple (CT) temperature sensor, use the designated compensation wire for extending wire.
- Keep away from high voltage lines or power lines to prevent inductive noise.
In case installing power line and input signal line closely, use line filter or varistor at power line and shielded wire at input signal line.
Do not use near the equipment which generates strong magnetic force or high frequency noise.
- Do not apply excessive power when connecting or disconnecting the connectors of the product.
- Install a power switch or circuit breaker in the easily accessible place for supplying or disconnecting the power.
- Do not use the unit for other purpose (e.g. voltmeter, ammeter), but temperature controller.
- 24VAC, 12-24VDC power supply should be insulated and limited voltage/current or Class 2, SELV power supply device.
- Make a required space around the unit for radiation of heat.
For accurate temperature measurement, warm up the unit over 20 min after turning on the power.
- Install a surge absorber at each end of inductive load coil when controlling high-capacity power relay or inductive load (e.g. magnet).
- Make sure that power supply voltage reaches to the rated voltage within 2 sec after supplying power.
- Do not wire to terminals which are not used.
- This unit may be used in the following environments.
 - ① Indoors (in the environment condition rated in 'Specifications')
 - ② Altitude max. 2,000m
 - ③ Pollution degree 2
 - ④ Installation category II

SENSORS
CONTROLLERS
MOTION DEVICES
SOFTWARE

(J) Temperature Controllers
(K) SSRs
(L) Power Controllers
(M) Counters
(N) Timers
(O) Digital Panel Meters
(P) Indicators
(Q) Converters
(R) Digital Display Units
(S) Sensor Controllers
(T) Switching Mode Power Supplies
(U) Recorders
(V) HMIs
(W) Panel PC
(X) Field Network Devices